

Slide Retainers

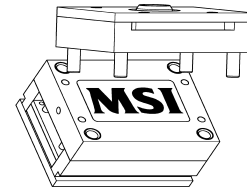

MSI Slide Retainers provide a compact method of slide retention that eliminates the use of springs or costly hydraulic systems. Interference with machine tie bars or safety gates is eliminated because the Slide Retainer can be installed behind or below the slide. They are made of case hardened steel and available in 3 sizes for slides up to 22, 44, and 88 pounds. They can also be used in multiples for larger or heavier slides. All Slide Retainers come supplied with dowel pin, spring, and shoulder screw.

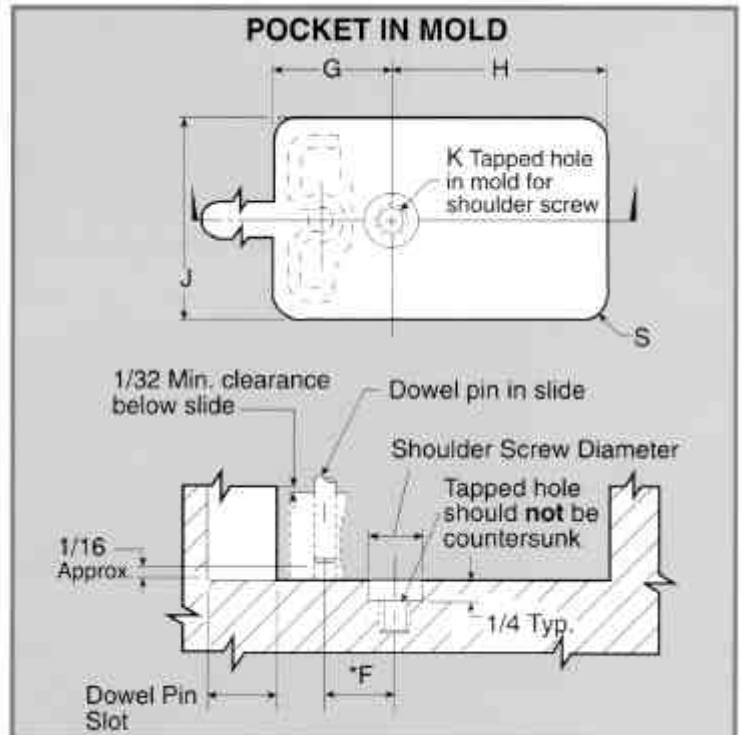
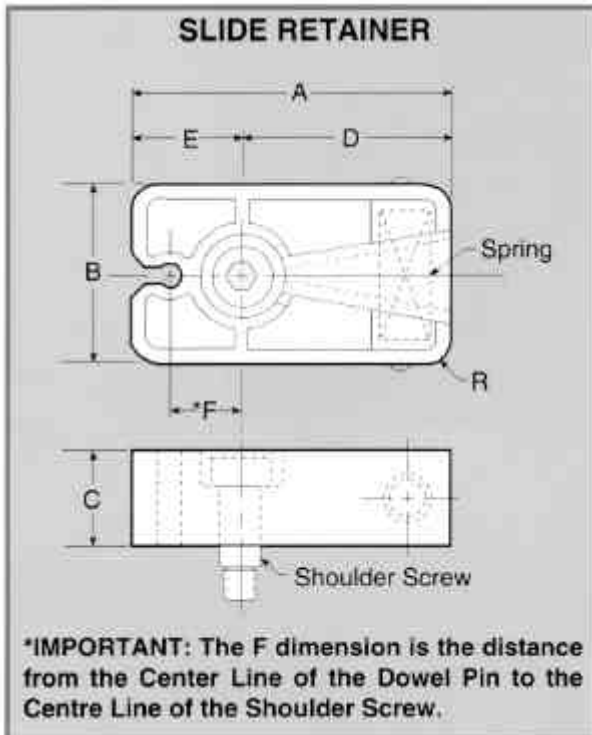
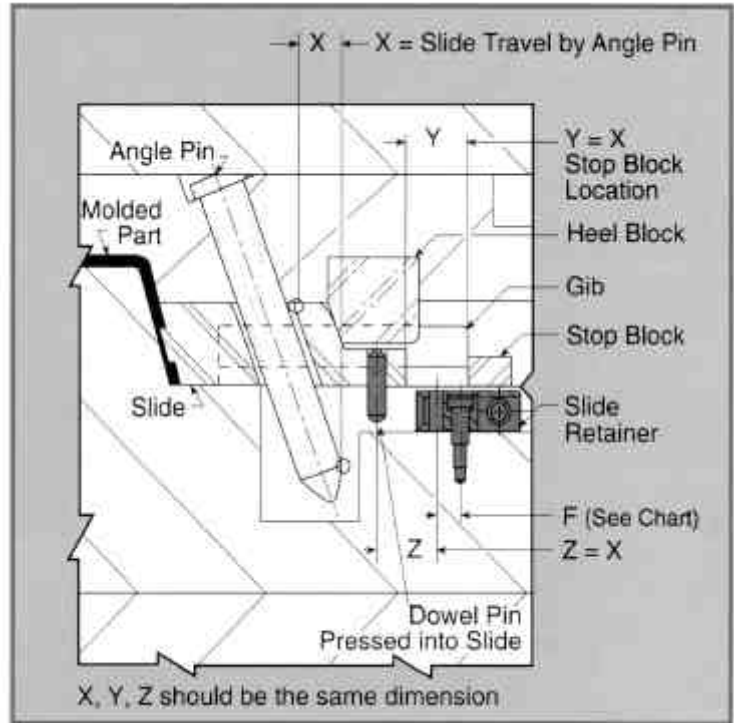

CATALOG NUMBER	A DIM.	B DIM.	C DIM.	D DIM.	E DIM.	*F DIM.	R RAD.	DOWEL PIN		MAXIMUM SLIDE WEIGHT	G DIM.	H DIM.	J DIM.	K DEPTH	SHOULDER SCREW		S RAD.
								DIA.	LGTH.						DIA.	LGTH.	
SRP-22	1 1/2"	3/4"	0.63	0.89	0.61	0.360	0.19	0.25	1 1/4"	22 POUNDS	0.73	1.01	1.0	10-24X1/2	0.250	0.625	0.31
SRP-44	2 1/8"	1 1/4"	0.79	1.31	0.81	0.500	0.25	0.312	1 1/2"	44 POUNDS	0.93	1.43	1.5	1/4-20X5/8	0.312	0.750	0.37
SRP-88	3 3/8"	1 3/4"	1.18	2.08	1.30	0.800	0.38	0.375	2 1/4"	88 POUNDS	1.42	2.20	2.0	5/16-18X5/8	0.375	1.000	0.50