

# MOLD SUPPLIES, INC.

## CARBIDE ENDMILL QUANTITY DISCOUNT SCHEDULE

Mold Supplies is offering the following discounts for volume purchases. You may mix & match any combination of end mills to reach desired quantity. This includes all tools on pages 2 - 23 in this catalog.

QUANTITY	DISCOUNT
10 - 19	10%
20 - 49	15%
50 - 100	25%

### CONTENTS

2-7 .....	Standard Endmills
8-17.....	High Performance/High Speed Milling
18-21 .....	Amorphous Diamond Coated Tools
22-24 .....	CVD Diamond Coated Tools
25-28 .....	Indexable Tools & Inserts

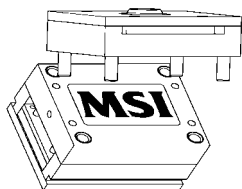

# Standard Length End Mills

## Economy Line

- General purpose carbide end mills
- 30 Deg. Helix rhs/rhe
- Made from premium micro grain carbide



+ .000 - .002 cutting diameter tolerance  
 + .000 - .0005 shank diameter tolerance

PART #		FLUTE DIA.	FLUTE LENGTH	SHANK DIA.	O.A.L	PRICE	
2 FLUTE	4 FLUTE					STANDARD	TIALN
EM2031	EM4031	1/32	3/32	1/8	1-1/2	\$7.00	\$8.56
EM2046	EM4046	3/64	1/8	1/8	1-1/2	\$7.00	\$8.56
EM2062	EM4062	1/16	1/4	1/8	1-1/2	\$5.00	\$6.56
EM2078	EM4078	5/64	1/4	1/8	1-1/2	\$5.00	\$6.56
EM2093	EM4093	3/32	3/8	1/8	1-1/2	\$5.00	\$6.56
EM2109	EM4109	7/64	3/8	1/8	1-1/2	\$5.00	\$6.56
EM2125	EM4125	1/8	1/2	1/8	1-1/2	\$5.50	\$7.06
EM2140	EM4140	9/64	9/16	3/16	2	\$9.00	\$11.00
EM2156	EM4156	5/32	9/16	3/16	2	\$9.00	\$11.00
EM2171	EM4171	11/64	9/16	3/16	2	\$9.00	\$11.00
EM2187	EM4187	3/16	5/8	3/16	2	\$7.00	\$9.00
EM2203	EM4203	13/64	5/8	1/4	2-1/2	\$11.00	\$15.10
EM2218	EM4218	7/32	5/8	1/4	2-1/2	\$11.00	\$15.10
EM2234	EM4234	15/64	3/4	1/4	2-1/2	\$11.00	\$15.10
EM2250	EM4250	1/4	3/4	1/4	2-1/2	\$9.30	\$13.40
EM2265	EM4265	17/64	7/8	5/16	2-1/2	\$14.00	\$20.10
EM2281	EM4281	9/32	7/8	5/16	2-1/2	\$14.00	\$20.10
EM2296	EM4296	19/64	7/8	5/16	2-1/2	\$14.00	\$20.10
EM2312	EM4312	5/16	7/8	5/16	2-1/2	\$12.00	\$18.10
EM2328	EM4328	21/64	7/8	3/8	2-1/2	\$15.00	\$21.10
EM2343	EM4343	11/32	7/8	3/8	2-1/2	\$15.00	\$21.10
EM2359	EM4359	23/64	7/8	3/8	2-1/2	\$15.00	\$21.10
EM2375	EM4375	3/8	7/8	3/8	2-1/2	\$13.00	\$19.10
EM2390	EM4390	25/64	7/8	7/16	2-1/2	\$21.00	\$28.56
EM2406	EM4406	13/32	7/8	7/16	2-1/2	\$21.00	\$28.56
EM2421	EM4421	27/64	7/8	7/16	2-1/2	\$21.00	\$28.56
EM2437	EM4437	7/16	1	7/16	2-1/2	\$19.00	\$26.56
EM2453	EM4453	29/64	1	1/2	3	\$25.00	\$32.56
EM2468	EM4468	15/32	1	1/2	3	\$25.00	\$32.56
EM2484	EM4484	31/64	1	1/2	3	\$25.00	\$32.56
EM2500	EM4500	1/2	1	1/2	3	\$20.90	\$28.46
EM2562	EM4562	9/16	1-1/4	9/16	3-1/2	\$37.00	\$47.96
EM2625	EM4625	5/8	1-1/4	5/8	3-1/2	\$47.00	\$57.96
EM2687	EM4687	11/16	1-1/2	3/4	4	\$75.00	\$87.94
EM2750	EM4750	3/4	1-1/2	3/4	4	\$64.00	\$76.94
EM2875	EM4875	7/8	1-1/2	7/8	4	\$110.00	\$129.10
EM2100	EM4100	1	1-1/2	1	4	\$110.00	\$129.10

FOR PRICING INFO. SEE PAGE 1



# Standard Length Ball End Mills

## Economy Line



- General purpose carbide end mills
- 30 Deg. Helix rhs/rhe
- Made from premium micro grain carbide

+.000 -.002 cutting diameter tolerance  
 +.000 -.0005 shank diameter tolerance

PART #		FLUTE DIA.	FLUTE LENGTH	SHANK DIA.	O.A.L	PRICE	
2 FLUTE	4 FLUTE					STANDARD	TIALN
BM2031	BM4031	1/32	3/32	1/8	1-1/2	\$9.00	\$10.56
BM2046	BM4046	3/64	1/8	1/8	1-1/2	\$9.00	\$10.56
BM2062	BM4062	1/16	1/4	1/8	1-1/2	\$7.00	\$8.56
BM2078	BM4078	5/64	1/4	1/8	1-1/2	\$7.00	\$8.56
BM2093	BM4093	3/32	3/8	1/8	1-1/2	\$7.00	\$8.56
BM2109	BM4109	7/64	3/8	1/8	1-1/2	\$7.00	\$8.56
BM2125	BM4125	1/8	1/2	1/8	1-1/2	\$6.50	\$8.06
BM2140	BM4140	9/64	9/16	3/16	2	\$11.00	\$13.00
BM2156	BM4156	5/32	9/16	3/16	2	\$11.00	\$13.00
BM2171	BM4171	11/64	9/16	3/16	2	\$11.00	\$13.00
BM2187	BM4187	3/16	5/8	3/16	2	\$10.00	\$12.00
BM2203	BM4203	13/64	5/8	1/4	2-1/2	\$14.00	\$18.10
BM2218	BM4218	7/32	5/8	1/4	2-1/2	\$14.00	\$18.10
BM2234	BM4234	15/64	3/4	1/4	2-1/2	\$14.00	\$18.10
BM2250	BM4250	1/4	3/4	1/4	2-1/2	\$11.70	\$15.80
BM2265	BM4265	17/64	7/8	5/16	2-1/2	\$16.50	\$22.62
BM2281	BM4281	9/32	7/8	5/16	2-1/2	\$16.50	\$22.62
BM2296	BM4296	19/64	7/8	5/16	2-1/2	\$16.50	\$22.62
BM2312	BM4312	5/16	7/8	5/16	2-1/2	\$14.50	\$20.62
BM2328	BM4328	21/64	7/8	3/8	2-1/2	\$20.00	\$26.12
BM2343	BM4343	11/32	7/8	3/8	2-1/2	\$20.00	\$26.12
BM2359	BM4359	23/64	7/8	3/8	2-1/2	\$20.00	\$26.12
BM2375	BM4375	3/8	7/8	3/8	2-1/2	\$19.00	\$25.12
BM2390	BM4390	25/64	7/8	7/16	2-1/2	\$26.00	\$33.56
BM2406	BM4406	13/32	7/8	7/16	2-1/2	\$26.00	\$33.56
BM2421	BM4421	27/64	7/8	7/16	2-1/2	\$26.00	\$33.56
BM2437	BM4437	7/16	1	7/16	2-1/2	\$24.00	\$31.56
BM2453	BM4453	29/64	1	1/2	3	\$31.00	\$38.56
BM2468	BM4468	15/32	1	1/2	3	\$31.00	\$38.56
BM2484	BM4484	31/64	1	1/2	3	\$31.00	\$38.56
BM2500	BM4500	1/2	1	1/2	3	\$27.00	\$34.56
BM2562	BM4562	9/16	1-1/4	9/16	3-1/2	\$47.00	\$57.96
BM2625	BM4625	5/8	1-1/4	5/8	3-1/2	\$59.00	\$69.96
BM2687	BM4687	11/16	1-1/2	3/4	4	\$85.00	\$97.94
BM2750	BM4750	3/4	1-1/2	3/4	4	\$76.00	\$88.94
BM2875	BM4875	7/8	1-1/2	7/8	4	\$150.00	\$169.10
BM2100	BM4100	1	1-1/2	1	4	\$150.00	\$169.10

FOR PRICING INFO. SEE PAGE 1

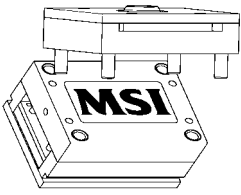

# Standard Length End Mills Premium Line



- ISO H6 Shank Tolerance for Shrink Fit Holders.
- +.000 -.001 Cutting Dia. Tolerance.
- Made From Ultra-Fine Micro Grain Carbide.
- 30 Deg. CNC - Qualified Helix.

PART #			FLUTE DIA.	FLUTE LENGTH	SHANK DIA.	O.A.L	PRICE	
2 FLUTE	3 FLUTE	4 FLUTE					STANDARD	MS3
12003110	13003110	14003110	1/32	3/32	1/8	1-1/2	\$9.09	\$11.18
12004610	13004610	14004610	3/64	1/8	1/8	1-1/2	\$9.09	\$11.18
12006210	13006210	14006210	1/16	1/4	1/8	1-1/2	\$8.47	\$10.56
12007810	13007810	14007810	5/64	1/4	1/8	1-1/2	\$8.47	\$10.56
12009310	13009310	14009310	3/32	3/8	1/8	1-1/2	\$8.02	\$10.12
12010910	13010910	14010910	7/64	3/8	1/8	1-1/2	\$8.02	\$10.12
12012510	13012510	14012510	1/8	1/2	1/8	1-1/2	\$7.44	\$9.54
12014010	13014010	14014010	9/64	9/16	3/16	2	\$11.31	\$13.98
12015610	13015610	14015610	5/32	9/16	3/16	2	\$11.31	\$13.98
12017110	13017110	14017110	11/64	9/16	3/16	2	\$11.31	\$13.98
12018710	13018710	14018710	3/16	5/8	3/16	2	\$10.78	\$13.44
12020310	13020310	14020310	13/64	5/8	1/4	2-1/2	\$14.60	\$20.07
12021810	13021810	14021810	7/32	5/8	1/4	2-1/2	\$14.60	\$20.07
12023410	13023410	14023410	15/64	3/4	1/4	2-1/2	\$14.60	\$20.07
12025010	13025010	14025010	1/4	3/4	1/4	2-1/2	\$13.42	\$18.89
12026510	13026510	14026510	17/64	7/8	5/16	2-1/2	\$23.29	\$31.45
12028110	13028110	14028110	9/32	7/8	5/16	2-1/2	\$23.29	\$31.45
12029610	13029610	14029610	19/64	7/8	5/16	2-1/2	\$23.29	\$31.45
12031210	13031210	14031210	5/16	7/8	5/16	2-1/2	\$19.11	\$27.27
12032810	13032810	14032810	21/64	7/8	3/8	2-1/2	\$27.71	\$35.87
12034310	13034310	14034310	11/32	7/8	3/8	2-1/2	\$27.71	\$35.87
12035910	13035910	14035910	23/64	7/8	3/8	2-1/2	\$27.71	\$35.87
12037510	13037510	14037510	3/8	7/8	3/8	2-1/2	\$23.80	\$31.96
12039010	13039010	14039010	25/64	7/8	7/16	2-1/2	\$36.53	\$46.61
12040610	13040610	14040610	13/32	7/8	7/16	2-1/2	\$36.53	\$46.61
12042110	13042110	14042110	27/64	7/8	7/16	2-1/2	\$36.53	\$46.61
12043710	13043710	14043710	7/16	1	7/16	2-1/2	\$30.80	\$40.88
12045310	13045310	14045310	29/64	1	1/2	3	\$44.84	\$54.92
12046810	13046810	14046810	15/32	1	1/2	3	\$44.84	\$54.92
12048410	13048410	14048410	31/64	1	1/2	3	\$44.84	\$54.92
12050010	13050010	14050010	1/2	1	1/2	3	\$38.38	\$48.46
12056210	13056210	14056210	9/16	1-1/4	9/16	3-1/2	\$65.40	\$80.01
12062510	13062510	14062510	5/8	1-1/4	5/8	3-1/2	\$74.44	\$89.06
12068710	13068710	14068710	11/16	1-1/2	3/4	4	\$123.58	\$140.84
12075010	13075010	14075010	3/4	1-1/2	3/4	4	\$110.87	\$128.13
12087510	13087510	14087510	7/8	1-1/2	7/8	4	\$161.82	\$187.28
12000010	13000010	14000010	1	1-1/2	1	4	\$170.62	\$196.08

FOR PRICING INFO. SEE PAGE 1

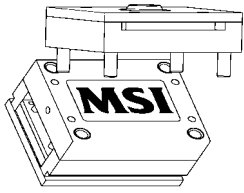

# Standard Length Ball End Mills

## Premium Line



- ISO H6 Shank Tolerance for Shrink Fit Holders.
- +.000 -.001 Cutting Dia. Tolerance.
- Made From Ultra-Fine Micro Grain Carbide.
- 30 Deg. CNC - Qualified Helix.

PART #			FLUTE DIA.	FLUTE LENGTH	SHANK DIA.	O.A.L	PRICE	
2 FLUTE	3 FLUTE	4 FLUTE					STANDARD	MS3
22003110	23003110	24003110	1/32	3/32	1/8	1-1/2	\$11.40	\$13.49
22004610	23004610	24004610	3/64	1/8	1/8	1-1/2	\$11.40	\$13.49
22006210	23006210	24006210	1/16	1/4	1/8	1-1/2	\$10.80	\$12.89
22007810	23007810	24007810	5/64	1/4	1/8	1-1/2	\$10.80	\$12.89
22009310	23009310	24009310	3/32	3/8	1/8	1-1/2	\$10.33	\$12.43
22010910	23010910	24010910	7/64	3/8	1/8	1-1/2	\$10.33	\$12.43
22012510	23012510	24012510	1/8	1/2	1/8	1-1/2	\$9.42	\$11.52
22014010	23014010	24014010	9/64	9/16	3/16	2	\$14.13	\$16.80
22015610	23015610	24015610	5/32	9/16	3/16	2	\$14.13	\$16.80
22017110	23017110	24017110	11/64	9/16	3/16	2	\$14.13	\$16.80
22018710	23018710	24018710	3/16	5/8	3/16	2	\$12.78	\$15.44
22020310	23020310	24020310	13/64	5/8	1/4	2-1/2	\$16.93	\$22.40
22021810	23021810	24021810	7/32	5/8	1/4	2-1/2	\$16.93	\$22.40
22023410	23023410	24023410	15/64	3/4	1/4	2-1/2	\$16.93	\$22.40
22025010	23025010	24025010	1/4	3/4	1/4	2-1/2	\$16.29	\$21.76
22026510	23026510	24026510	17/64	7/8	5/16	2-1/2	\$25.51	\$33.67
22028110	23028110	24028110	9/32	7/8	5/16	2-1/2	\$25.51	\$33.67
22029610	23029610	24029610	19/64	7/8	5/16	2-1/2	\$25.51	\$33.67
22031210	23031210	24031210	5/16	7/8	5/16	2-1/2	\$21.80	\$29.96
22032810	23032810	24032810	21/64	7/8	3/8	2-1/2	\$30.64	\$38.80
22034310	23034310	24034310	11/32	7/8	3/8	2-1/2	\$30.64	\$38.80
22035910	23035910	24035910	23/64	7/8	3/8	2-1/2	\$30.64	\$38.80
22037510	23037510	24037510	3/8	7/8	3/8	2-1/2	\$26.71	\$34.87
22039010	23039010	24039010	25/64	7/8	7/16	2-1/2	\$40.09	\$50.17
22040610	23040610	24040610	13/32	7/8	7/16	2-1/2	\$40.09	\$50.17
22042110	23042110	24042110	27/64	7/8	7/16	2-1/2	\$40.09	\$50.17
22043710	23043710	24043710	7/16	1	7/16	2-1/2	\$35.27	\$45.35
22045310	23045310	24045310	29/64	1	1/2	3	\$53.78	\$63.86
22046810	23046810	24046810	15/32	1	1/2	3	\$53.78	\$63.86
22048410	23048410	24048410	31/64	1	1/2	3	\$53.78	\$63.86
22050010	23050010	24050010	1/2	1	1/2	3	\$49.16	\$59.24
22056210	23056210	24056210	9/16	1-1/4	9/16	3-1/2	\$72.76	\$87.37
22062510	23062510	24062510	5/8	1-1/4	5/8	3-1/2	\$81.58	\$96.19
22068710	23068710	24068710	11/16	1-1/2	3/4	4	\$135.40	\$152.67
22075010	23075010	24075010	3/4	1-1/2	3/4	4	\$121.71	\$138.98
22087510	23087510	24087510	7/8	1-1/2	7/8	4	\$194.44	\$219.90
22000010	23000010	24000010	1	1-1/2	1	4	\$211.76	\$237.21

FOR PRICING INFO. SEE PAGE 1

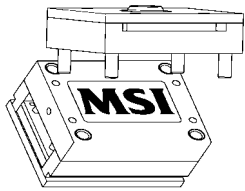

# Extra Length End Mills Premium Line

- ISO H6 Shank Tolerance for Shrink Fit Holders.
- +.000 -.001 Cutting Dia. Tolerance.
- Made From Ultra-Fine Micro Grain Carbide.
- 30 Deg. CNC - Qualified Helix.

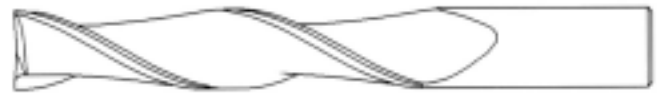

PART #		FLUTE DIA.	FLUTE LENGTH	SHANK DIA.	O.A.L.	PRICE	
2 FLUTE	4 FLUTE					STANDARD	MS3
12112510	14112510	1/8	5/8	1/8	2	\$11.13	\$13.23
12312510	14312510	1/8	3/4	1/8	3	\$16.82	\$19.49
12412510	14412510	1/8	1	1/8	3	\$16.82	\$19.49
12118710	14118710	3/16	1	3/16	3	\$21.29	\$25.42
12218710	14218710	3/16	1-1/8	3/16	3	\$21.29	\$25.42
12318710	14318710	3/16	1	3/16	4	\$23.67	\$28.48
12125010	14125010	1/4	1	1/4	3	\$22.44	\$27.91
12325010	14325010	1/4	1	1/4	4	\$27.31	\$33.74
12425010	14425010	1/4	1-1/2	1/4	4	\$27.31	\$33.74
12525010	14525010	1/4	1-1/2	1/4	6	\$36.22	\$45.29
12131210	14131210	5/16	1	5/16	3	\$28.04	\$36.20
12331210	14331210	5/16	1	5/16	4	\$31.98	\$42.43
12431210	14431210	5/16	1-5/8	5/16	4	\$31.98	\$42.43
12531210	14531210	5/16	1-1/2	5/16	6	\$47.82	\$61.93
12137510	14137510	3/8	1	3/8	3	\$31.96	\$40.12
12337510	14337510	3/8	1	3/8	4	\$35.98	\$46.43
12437510	14437510	3/8	2	3/8	4	\$35.98	\$46.43
12537510	14537510	3/8	1-1/2	3/8	6	\$52.49	\$66.60
12143710	14143710	7/16	1	7/16	4	\$47.93	\$61.04
12443710	14443710	7/16	2	7/16	4	\$47.93	\$61.04
12543710	14543710	7/16	1-1/2	7/16	6	\$72.76	\$91.16
12643710	14643710	7/16	3	7/16	6	\$72.76	\$91.16
12150010	14150010	1/2	1	1/2	4	\$53.53	\$66.64
12250010	14250010	1/2	2	1/2	4	\$53.53	\$66.64
12550010	14550010	1/2	1-1/2	1/2	6	\$78.18	\$96.58
12650010	14650010	1/2	3	1/2	6	\$78.18	\$96.58
12556210	14556210	9/16	2	9/16	6	\$101.87	\$123.53
12656210	14656210	9/16	3	9/16	6	\$101.87	\$123.53
12562510	14562510	5/8	2	5/8	6	\$113.00	\$134.67
12662510	14662510	5/8	3	5/8	6	\$113.00	\$134.67
12575010	14575010	3/4	2	3/4	6	\$177.31	\$202.39
12675010	14675010	3/4	3	3/4	6	\$177.31	\$202.39
12500010	14500010	1	2	1	6	\$295.67	\$328.31
12600010	14600010	1	3	1	6	\$295.67	\$328.31

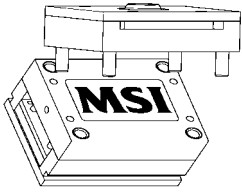

# Extra Length Ball End Mills

## Premium Line

- ISO H6 Shank Tolerance for Shrink Fit Holders.
- +.000 -.001 Cutting Dia. Tolerance.
- Made From Ultra-Fine Micro Grain Carbide.
- 30 Deg. CNC - Qualified Helix.

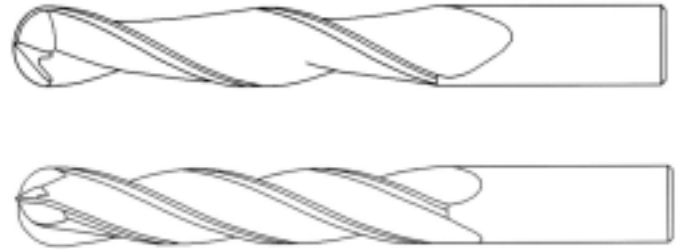

PART NUMBER		FLUTE DIA.	FLUTE LENGTH	SHANK DIA.	O.A.L.	PRICE	
2 FLUTE	4 FLUTE					STANDARD	MS3
22112510	24112510	1/8	5/8	1/8	2	\$12.96	\$15.05
22312510	24312510	1/8	3/4	1/8	3	\$19.62	\$22.29
22412510	24412510	1/8	1	1/8	3	\$23.20	\$25.87
22118710	24118710	3/16	1	3/16	3	\$24.36	\$28.49
22218710	24218710	3/16	1-1/8	3/16	3	\$24.36	\$28.49
22318710	24318710	3/16	1	3/16	4	\$26.51	\$31.32
22125010	24125010	1/4	1	1/4	3	\$26.00	\$31.47
22325010	24325010	1/4	1	1/4	4	\$31.91	\$38.34
22425010	24425010	1/4	1-1/2	1/4	4	\$31.91	\$38.34
22525010	24525010	1/4	1-1/2	1/4	6	\$38.60	\$47.67
22131210	24131210	5/16	1	5/16	3	\$32.47	\$40.63
22331210	24331210	5/16	1	5/16	4	\$36.91	\$47.36
22431210	24431210	5/16	1-5/8	5/16	4	\$36.91	\$47.36
22531210	24531210	5/16	1-1/2	5/16	6	\$55.09	\$69.20
22137510	24137510	3/8	1	3/8	3	\$36.89	\$45.05
22337510	24337510	3/8	1	3/8	4	\$41.78	\$52.23
22437510	24437510	3/8	2	3/8	4	\$41.78	\$52.23
22537510	24537510	3/8	1-1/2	3/8	6	\$57.89	\$72.00
22143710	24143710	7/16	1	7/16	4	\$55.44	\$68.55
22443710	24443710	7/16	2	7/16	4	\$55.44	\$68.55
22543710	24543710	7/16	1-1/2	7/16	6	\$78.18	\$96.58
22643710	24643710	7/16	3	7/16	6	\$78.18	\$96.58
22150010	24150010	1/2	1	1/2	4	\$59.40	\$72.51
22250010	24250010	1/2	2	1/2	4	\$59.40	\$72.51
22550010	24550010	1/2	1-1/2	1/2	6	\$85.13	\$103.53
22650010	24650010	1/2	3	1/2	6	\$85.13	\$103.53
22556210	24556210	9/16	2	9/16	6	\$116.98	\$138.64
22656210	24656210	9/16	3	9/16	6	\$116.98	\$138.64
22562510	24562510	5/8	2	5/8	6	\$126.18	\$147.84
22662510	24662510	5/8	3	5/8	6	\$126.18	\$147.84
22575010	24575010	3/4	2	3/4	6	\$203.42	\$228.50
22675010	24675010	3/4	3	3/4	6	\$203.42	\$228.50
22500010	24500010	1	2	1	6	\$340.13	\$372.77
22600010	24600010	1	3	1	6	\$340.13	\$372.77



# HIGH PERFORMANCE SERIES

## 5 FLUTE FLAT END MILLS

- ISO H6 Shank Tolerance for Shrink Fit Holders.
- Tool Runout < .0004
- Made From Ultra-Fine Micro Grain Carbide.
- 45° CNC - Qualified Helix.
- MS3 Coated

# HF15

SERIES



PART NUMBER	FLUTE DIA.	SHANK DIA.	FLUTE LENGTH	O.A.L.	PRICE
HF15012517	1/8	1/8	1/2	1-1/2	\$15.73
HF15112517	1/8	1/8	5/8	2	\$20.48
HF15312517	1/8	1/8	3/4	3	\$29.68
HF15015617	5/32	3/16	9/16	2	\$22.68
HF15018717	3/16	3/16	5/8	2	\$20.60
HF15118717	3/16	3/16	1	3	\$32.80
HF15318717	3/16	3/16	1	4	\$35.95
HF15021817	7/32	1/4	5/8	2-1/2	\$28.75
HF15025017	1/4	1/4	3/4	2-1/2	\$23.28
HF15325017	1/4	1/4	1	4	\$33.51
HF15525017	1/4	1/4	1-1/2	6	\$51.86
HF15031217	5/16	5/16	7/8	2-1/2	\$34.51
HF15331217	5/16	5/16	1	4	\$52.62
HF15531217	5/16	5/16	1-1/2	6	\$81.55
HF15037517	3/8	3/8	1	2-1/2	\$42.68
HF15337517	3/8	3/8	1-1/2	4	\$55.80
HF15043717	7/16	7/16	1	2-1/2	\$50.35
HF15143717	7/16	7/16	1	4	\$74.00
HF15050017	1/2	1/2	1-1/4	3	\$63.77
HF15250017	1/2	1/2	2	4	\$92.88
HF15062517	5/8	5/8	1-1/4	3-1/2	\$108.15
HF15075017	3/4	3/4	1-1/2	4	\$148.17



# HIGH PERFORMANCE SERIES

5 FLUTE SIDEWALL FINISHING END MILLS  
MOLD FINISHING / HARD MILLING / HIGH SPEED

# HF15

SERIES

- H6 SHANK TOLERANCE FOR SHRINK FIT HOLDERS
- TOOL RUNOUT < .0004
- ULTRA FINE MICRO-GRAIN CARBIDE
- 45° CNC -QUALIFIED HELIX
- MS3 COATING



## HF15 SERIES

PART NUMBER	FLUTE DIA.	SHANK DIA.	FLUTE LENGTH	O.A.L.	PRICE
HF15350017	1/2	1/2	2	4	\$91.20
HF15450017	1/2	1/2	3	6	\$140.00
HF15550017	1/2	1/2	4	6	\$140.00
HF15650017	1/2	1/2	5-1/2	8	CALL
HF15362517	5/8	5/8	2	4	\$136.11
HF15462517	5/8	5/8	3	6	\$188.47
HF15562517	5/8	5/8	4	6	\$188.47
HF15662517	5/8	5/8	6	8	CALL
HF15375017	3/4	3/4	2	4	\$179.69
HF15475017	3/4	3/4	3	6	\$242.96
HF15575017	3/4	3/4	4	6	\$242.96
HF15675017	3/4	3/4	6	8	CALL
HF15300017	1	1	2	4	\$243.64
HF15400017	1	1	3	6	\$393.82
HF15500017	1	1	4	6	\$393.82
HF15600017	1	1	6	8	CALL



# HIGH PERFORMANCE SERIES

## 5 FLUTE CORNER RADIUS END MILLS MOLD FINISHING / HARD MILLING / HIGH SPEED

# HF35

SERIES

- H6 SHANK TOLERANCE FOR SHRINK FIT HOLDERS
- TOOL RUNOUT < .0004
- ULTRA FINE MICRO-GRAIN CARBIDE
- 45° CNC -QUALIFIED HELIX
- MS3 COATING



### HF35 SERIES

PART NUMBER	FLUTE DIA.	RADIUS	SHANK DIA.	FLUTE LENGTH	O.A.L.	PRICE
HF35025017-015	1/4	1/64	1/4	3/4	2-1/2	\$28.40
HF35025017-030	1/4	1/32	1/4	3/4	2-1/2	\$28.40
HF35025017-060	1/4	1/16	1/4	3/4	2-1/2	\$28.40
HF35325017-015	1/4	1/64	1/4	1	3	\$39.78
HF35325017-030	1/4	1/32	1/4	1	3	\$39.78
HF35325017-060	1/4	1/16	1/4	1	3	\$39.78
HF35525017-015	1/4	1/64	1/4	1-1/2	6	\$61.10
HF35525017-030	1/4	1/32	1/4	1-1/2	6	\$61.10
HF35525017-060	1/4	1/16	1/4	1-1/2	6	\$61.10
HF35031217-015	5/16	1/64	5/16	7/8	2-1/2	\$38.42
HF35031217-030	5/16	1/32	5/16	7/8	2-1/2	\$38.42
HF35031217-060	5/16	1/16	5/16	7/8	2-1/2	\$38.42
HF35431217-015	5/16	1/64	5/16	1	4	\$55.71
HF35431217-030	5/16	1/32	5/16	1	4	\$55.71
HF35431217-060	5/16	1/16	5/16	1	4	\$55.71
HF35531217-015	5/16	1/64	5/16	1-5/8	6	\$76.46
HF35531217-030	5/16	1/32	5/16	1-5/8	6	\$76.46
HF35531217-060	5/16	1/16	5/16	1-5/8	6	\$76.46
HF35037517-015	3/8	1/64	3/8	7/8	2-1/2	\$42.56
HF35037517-030	3/8	1/32	3/8	7/8	2-1/2	\$42.56
HF35037517-060	3/8	1/16	3/8	7/8	2-1/2	\$42.56
HF35337517-015	3/8	1/64	3/8	1	4	\$59.93
HF35337517-030	3/8	1/32	3/8	1	4	\$59.93
HF35337517-060	3/8	1/16	3/8	1	4	\$59.93
HF35537517-015	3/8	1/64	3/8	1-1/2	6	\$83.93
HF35537517-030	3/8	1/32	3/8	1-1/2	6	\$83.93
HF35537517-060	3/8	1/16	3/8	1-1/2	6	\$83.93
HF35050017-015	1/2	1/64	1/2	1	3	\$72.56
HF35050017-030	1/2	1/32	1/2	1	3	\$72.56
HF35050017-060	1/2	1/16	1/2	1	3	\$72.56
HF35050017-125	1/2	1/8	1/2	1	3	\$72.56
HF35150017-015	1/2	1/64	1/2	1	4	\$80.29
HF35150017-030	1/2	1/32	1/2	1	4	\$80.29
HF35150017-060	1/2	1/16	1/2	1	4	\$80.29
HF35150017-125	1/2	1/8	1/2	1	4	\$80.29



# HIGH PERFORMANCE SERIES

## 5 FLUTE CORNER RADIUS END MILLS MOLD FINISHING / HARD MILLING / HIGH SPEED

# HF35

SERIES

- H6 SHANK TOLERANCE FOR SHRINK FIT HOLDERS
- TOOL RUNOUT < .0004
- ULTRA FINE MICRO-GRAIN CARBIDE
- 45° CNC -QUALIFIED HELIX
- MS3 COATING



### HF35 SERIES

PART NUMBER	FLUTE DIA.	RADIUS	SHANK DIA.	FLUTE LENGTH	O.A.L.	PRICE
HF35550017-015	1/2	1/64	1/2	1-1/2	6	\$121.44
HF35550017-030	1/2	1/32	1/2	1-1/2	6	\$121.44
HF35550017-060	1/2	1/16	1/2	1-1/2	6	\$121.44
HF35550017-125	1/2	1/8	1/2	1-1/2	6	\$121.44
HF35062517-015	5/8	1/64	5/8	1-1/4	3-1/2	\$112.13
HF35062517-030	5/8	1/32	5/8	1-1/4	3-1/2	\$112.13
HF35062517-060	5/8	1/16	5/8	1-1/4	3-1/2	\$112.13
HF35062517-125	5/8	1/8	5/8	1-1/4	3-1/2	\$112.13
HF35562517-015	5/8	1/64	5/8	2	6	\$171.42
HF35562517-030	5/8	1/32	5/8	2	6	\$171.42
HF35562517-060	5/8	1/16	5/8	2	6	\$171.42
HF35562517-125	5/8	1/8	5/8	2	6	\$171.42
HF35075017-015	3/4	1/64	3/4	1-1/2	4	\$160.78
HF35075017-030	3/4	1/32	3/4	1-1/2	4	\$160.78
HF35075017-060	3/4	1/16	3/4	1-1/2	4	\$160.78
HF35075017-125	3/4	1/8	3/4	1-1/2	4	\$160.78
HF35575017-015	3/4	1/64	3/4	2	6	\$258.27
HF35575017-030	3/4	1/32	3/4	2	6	\$258.27
HF35575017-060	3/4	1/16	3/4	2	6	\$258.27
HF35575017-125	3/4	1/8	3/4	2	6	\$258.27
HF35000017-015	1	1/64	1	1-1/2	4	\$268.13
HF35000017-030	1	1/32	1	1-1/2	4	\$268.13
HF35000017-060	1	1/16	1	1-1/2	4	\$268.13
HF35000017-125	1	1/8	1	1-1/2	4	\$268.13
HF35500017-015	1	1/64	1	2	6	\$410.47
HF35500017-030	1	1/32	1	2	6	\$410.47
HF35500017-060	1	1/16	1	2	6	\$410.47
HF35500017-125	1	1/8	1	2	6	\$410.47

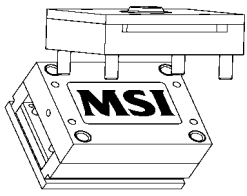

# HIGH PERFORMANCE SERIES

5 FLUTE CORNER RADIUS END MILLS  
MOLD FINISHING / HARD MILLING / HIGH SPEED

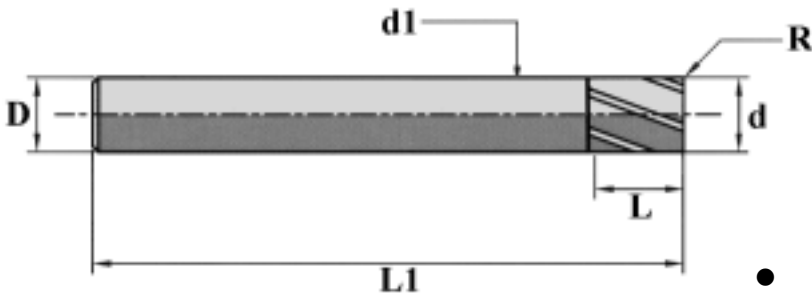

# HS35

SERIES

- H6 SHANK TOLERANCE FOR SHRINK FIT HOLDERS
- TOOL RUNOUT < .0004
- ULTRA FINE MICRO-GRAIN CARBIDE
- 20° CNC -QUALIFIED HELIX
- MS3 COATING

## HS35 SERIES

EDP #	d	L	D	L1	Z	R	PRICE
HS35012517-015	1/8	1/2	1/8	1-1/2	5	0.015	\$20.17
HS35012517-030	1/8	1/2	1/8	1-1/2	5	0.030	\$20.17
HS35018717-015	3/16	5/8	3/16	2	5	0.015	\$21.06
HS35018717-030	3/16	5/8	3/16	2	5	0.030	\$21.06
HS35025017-030	1/4	3/4	1/4	2-1/2	5	0.030	\$28.40
HS35025017-060	1/4	3/4	1/4	2-1/2	5	0.060	\$28.40
HS35031217-030	5/16	7/8	5/16	2-1/2	5	0.030	\$37.26
HS35031217-060	5/16	7/8	5/16	2-1/2	5	0.060	\$37.26
HS35037517-030	3/8	7/8	3/8	2-1/2	5	0.030	\$42.55
HS35037517-060	3/8	7/8	3/8	2-1/2	5	0.060	\$42.55
HS35043717-030	7/16	1	7/16	3	5	0.030	\$56.93
HS35043717-060	7/16	1	7/16	3	5	0.060	\$56.93
HS35050017-030	1/2	1	1/2	3	5	0.030	\$72.57
HS35050017-060	1/2	1	1/2	3	5	0.060	\$72.57

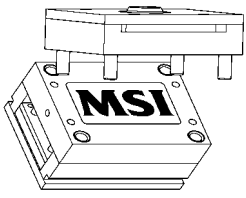

# HIGH PERFORMANCE SERIES

4 FLUTE CORNER RADIUS END MILLS  
MOLD FINISHING / HARD MILLING / HIGH SPEED

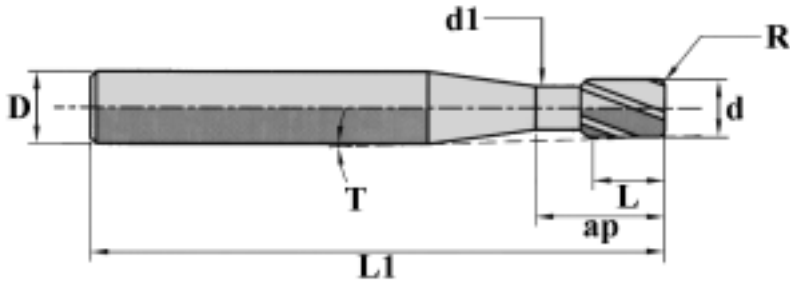

# HS34

SERIES

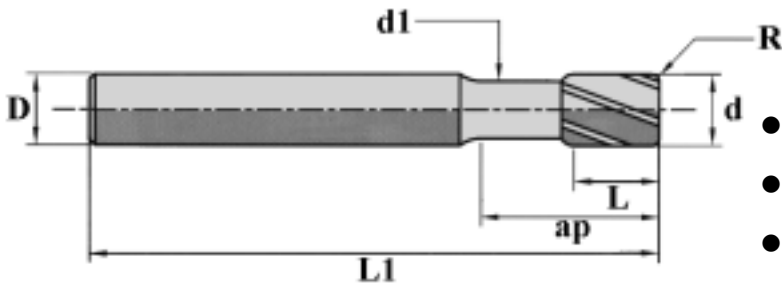

- H6 SHANK TOLERANCE FOR SHRINK FIT HOLDERS
- TOOL RUNOUT < .0004
- ULTRA FINE MICRO-GRAIN CARBIDE
- MS3 COATING

## HS34 SERIES

EDP #	d	L	D	L1	Z	ap	R	PRICE
HS34006217-015	1/16	5/64	1/4	2 1/2	4	5/32	0.015	\$51.00
HS34009317-015	3/32	1/8	1/4	2 1/2	4	7/32	0.015	\$51.00
HS34012517-015	1/8	5/32	1/4	2 1/2	4	9/32	0.015	\$51.00
HS34012517-030	1/8	5/32	1/4	2 1/2	4	9/32	0.030	\$51.00
HS34018717-030	3/16	15/64	1/4	2 1/2	4	7/16	0.030	\$51.00
HS34025017-015	1/4	5/16	1/4	2 1/2	4	9/16	0.015	\$48.50
HS34025017-030	1/4	5/16	1/4	2 1/2	4	9/16	0.030	\$48.50
HS34031217-030	5/16	25/64	5/16	2 1/2	4	11/16	0.030	\$55.80
HS34037517-030	3/8	15/32	3/8	3	4	15/16	0.030	\$59.48
HS34037517-060	3/8	15/32	3/8	3	4	15/16	0.060	\$59.48
HS34050017-030	1/2	5/8	1/2	3	4	1 1/8	0.030	\$67.99
HS34050017-060	1/2	5/8	1/2	3	4	1 1/8	0.060	\$67.99
HS34062517-060	5/8	25/32	5/8	4	4	1 1/2	0.060	

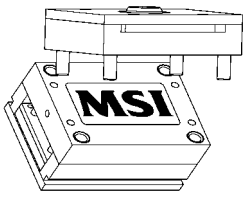

# HIGH PERFORMANCE SERIES

## 2 FLUTE FINISHING BALL MOLD FINISHING / HARD MILLING / HIGH SPEED

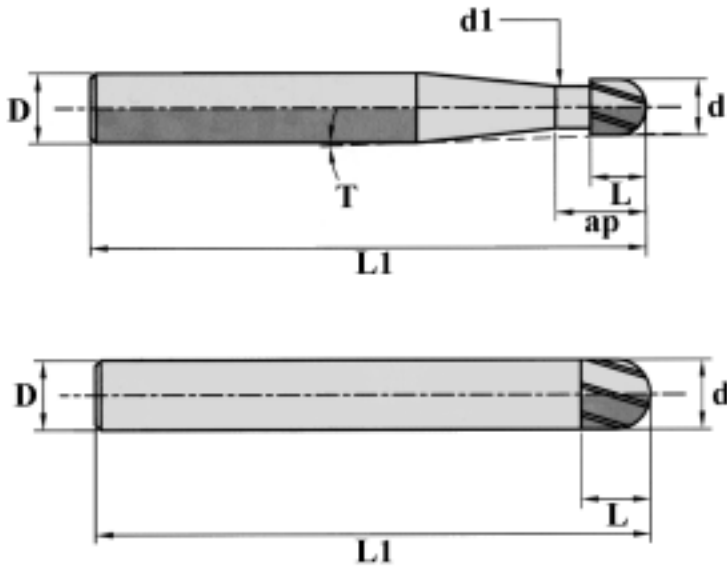

# HB2

SERIES

- H6 SHANK TOLERANCE FOR SHRINK FIT HOLDERS
- TOOL RUNOUT < .0004
- ULTRA FINE MICRO-GRAIN CARBIDE
- MS3 COATING

### HB2 SERIES

EDP #	d	L	D	L1	Z	ap	R	PRICE
HB22003217	1/32	1/32	1/4	3	2	1/16	BALL	\$52.11
HB22903217	1/32	1/16	1/8	2	2	1/16	BALL	\$24.32
HB22006217	1/16	1/16	1/4	3	2	1/8	BALL	\$52.11
HB22906217	1/16	1/8	1/8	2	2	1/8	BALL	\$24.32
HB22009317	3/32	3/32	1/4	3	2	3/16	BALL	\$52.11
HB22909317	3/32	3/16	1/8	2	2	3/16	BALL	\$24.32
HB22012517	1/8	1/8	1/4	3	2	1/4	BALL	\$47.67
HB22912517	1/8	1/4	1/8	2	2	-	BALL	\$23.20
HB22512517	1/8	1/8	1/4	4	2	1/4	BALL	\$53.83
HB22912617	1/8	1/4	1/8	3	2	-	BALL	\$35.29
HB22018717	3/16	3/16	1/4	3	2	3/8	BALL	\$47.67
HB22918717	3/16	3/8	3/16	2	2	3/8	BALL	\$26.00
HB22025017	1/4	1/4	1/4	3	2	-	BALL	\$38.78
HB22325017	1/4	1/4	1/4	4	2	-	BALL	\$42.18
HB22031217	5/16	5/16	5/16	3	2	-	BALL	\$50.24
HB22231217	5/16	5/16	5/16	4	2	-	BALL	\$62.72
HB22037517	3/8	3/8	3/8	4	2	-	BALL	\$55.57
HB22537517	3/8	3/8	3/8	6	2	-	BALL	\$69.42
HB22050017	1/2	1/2	1/2	4	2	-	BALL	\$77.02
HB22550017	1/2	1/2	1/2	6	2	-	BALL	\$101.07

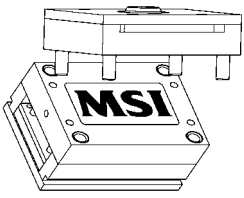

# HIGH PERFORMANCE SERIES

## 4 FLUTE FINISHING BALL MOLD FINISHING / HARD MILLING / HIGH SPEED

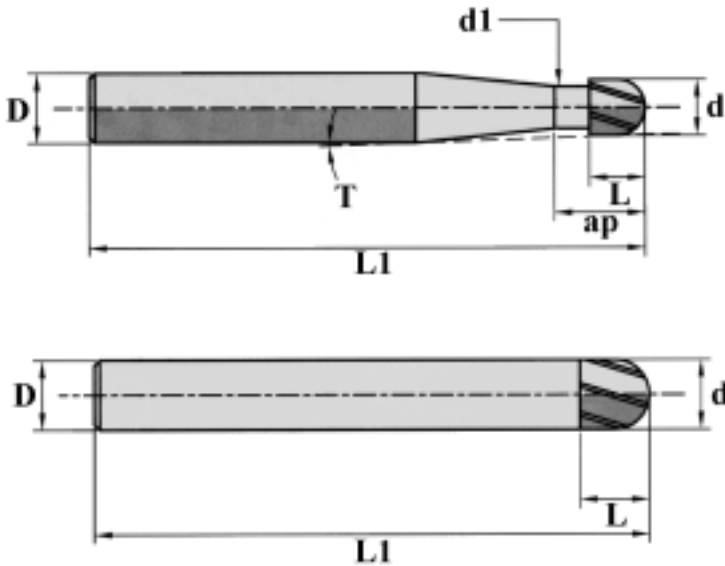

# HB4

SERIES

- ALL 4 FLUTES COME TO THE CENTER
- EXCELLENT ON HARD MATERIALS >50HRC
- H6 SHANK TOLERANCE FOR SHRINK FIT HOLDERS
- TOOL RUNOUT < .0004
- ULTRA FINE MICRO-GRAIN CARBIDE

### HB4 SERIES

EDP #	d	L	D	L1	Z	ap	R	PRICE
HB24025017	1/4	3/8	1/4	3"	4	3/8	BALL	\$52.15
HB24031217	5/16	15/32	5/16	3"	4	15/32	BALL	\$65.00
HB24037517	3/8	9/16	3/8	3"	4	9/16	BALL	\$72.40
HB24137517	3/8	9/16	3/8	4"	4	9/16	BALL	\$80.80
HB24050017	1/2	3/4	1/2	3"	4	3/4	BALL	\$103.20
HB24150017	1/2	3/4	1/2	4"	4	3/4	BALL	\$115.00

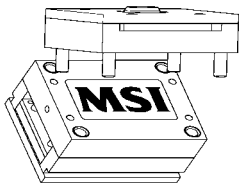

# TOOL SELECTION GUIDE

Tool Selection and Tool Application for the HB2, HB4, HS3, and HF3 Series End Mills for:

## *Mold Finishing/Hard Milling/High Speed Machining*

MATERIAL	Tool Selection			Tool Impact		
				ae = Radial Width ap = Axial Depth		
	SLOT	PROFILE	COPY	SLOT	PROFILE	COPY
TOOL STEEL < 48 Rc.	HS34...	HF35... HS34...	HB22...	ROUGH ae 1xd ap 0.046xd FINISH ae 1xd ap 0.020xd	ROUGH ae 0.035xd ap 0.820xd FINISH ae 0.020xd ap 0.650xd	ROUGH ae 0.020xd ap 0.030xd FINISH ae 0.010xd ap 0.020xd
TOOL STEEL >48<=55	HS34...	HF35... HS35... HS34...	HB22... HB24...	ROUGH ae 1xd ap 0.044xd FINISH ae 1xd ap 0.020xd	ROUGH ae 0.033xd ap 0.820xd FINISH ae 0.020xd ap 0.650xd	ROUGH ae 0.020xd ap 0.030xd FINISH ae 0.010xd ap 0.020xd
TOOL STEEL >55HRC	HS34...	HS35... HS34... HF35...	HB24... HB22...	ROUGH ae 1xd ap 0.028xd FINISH ae 1xd ap 0.010xd	ROUGH ae 0.028xd ap 0.750xd FINISH ae 0.010xd ap 0.450xd	ROUGH ae 0.020xd ap 0.020xd FINISH ae 0.010xd ap 0.010xd
STAINLEES STEEL	HS34...	HF35...	HB22...	ROUGH ae 1xd ap 0.040xd FINISH ae 1xd ap 0.010xd	ROUGH ae 0.020xd ap 0.830xd FINISH ae 0.010xd ap 0.580xd	ROUGH ae 0.020xd ap 0.030xd FINISH ae 0.010xd ap 0.020xd
CAST IRON	HS34...	HF35... HS34...	HB22... HB24...	ROUGH ae 1xd ap 0.042xd FINISH ae 1xd ap 0.020xd	ROUGH ae 0.021xd ap 0.850xd FINISH ae 0.010xd ap 0.640xd	ROUGH ae 0.030xd ap 0.040xd FINISH ae 0.020xd ap 0.020xd

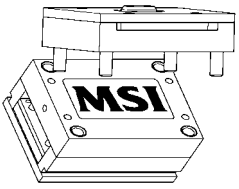

# TOOL SELECTION GUIDE

Tool Selection and Tool Application for the HB2, HS36,  
and HF3 Series End Mills for:

## *Mold Finishing/Hard Milling/High Speed Machining*

MATERIAL	SF	APPLICATION	CHIPLOAD 1/16 - 1/8	CHIPLOAD 3/16 - 1/4	CHIPLOAD 5/16 - 3/8	CHIPLOAD 1/2 - 5/8	CHIPLOAD 9/16 - 1"
TOOL STEEL < 48 Rc.	540	ROUGHING	0.0005	0.0011	0.0022	0.0033	0.0043
	930		0.0009	0.0017	0.0035	0.0053	0.0070
	1130		0.0009	0.0020	0.0035	0.0058	0.0077
	690	FINISHING	0.0006	0.0013	0.0026	0.0038	0.0050
	1170		0.0009	0.0020	0.0039	0.0059	0.0078
	1280		0.0010	0.0022	0.0043	0.0065	0.0086
TOOL STEEL >48<=55	525	ROUGHING	0.0005	0.0011	0.0022	0.0033	0.0043
	900		0.0008	0.0016	0.0033	0.0050	0.0066
	1090		0.0009	0.0018	0.0037	0.0055	0.0073
	660	FINISHING	0.0005	0.0011	0.0023	0.0035	0.0046
	1120		0.0009	0.0018	0.0035	0.0053	0.0071
	1230		0.0009	0.0020	0.0039	0.0059	0.0078
TOOL STEEL >55HRC	240	ROUGHING	0.0004	0.0008	0.0017	0.0026	0.0036
	400		0.0006	0.0012	0.0026	0.0039	0.0056
	475		0.0007	0.0014	0.0031	0.0047	0.0067
	280	FINISHING	0.0005	0.0009	0.0019	0.0029	0.0042
	460		0.0007	0.0014	0.0029	0.0045	0.0065
	490		0.0007	0.0015	0.0031	0.0048	0.0070
STAINLEES STEEL	280	ROUGHING	0.0004	0.0009	0.0017	0.0026	0.0043
	460		0.0007	0.0014	0.0029	0.0042	0.0071
	560		0.0007	0.0015	0.0030	0.0045	0.0076
	360	FINISHING	0.0005	0.0010	0.0020	0.0029	0.0050
	590		0.0007	0.0017	0.0033	0.0049	0.0082
	700		0.0009	0.0018	0.0035	0.0052	0.0088
CAST IRON	490	ROUGHING	0.0005	0.0011	0.0023	0.0033	0.0044
	800		0.0008	0.0017	0.0035	0.0051	0.0069
	1000		0.0009	0.0019	0.0038	0.0056	0.0076
	570	FINISHING	0.0006	0.0012	0.0024	0.0036	0.0048
	940		0.0009	0.0018	0.0037	0.0055	0.0075
	1070		0.0010	0.0020	0.0041	0.0061	0.0082

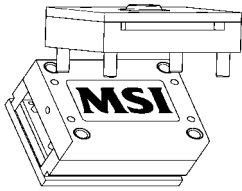

# AD-98 END MILLS

FOR MACHINING GRAPHITE AND CARBON COMPOSITES

- ISO H6 Shank Tolerance for Shrink Fit Holders.
- Made From Ultra-Fine Micro Grain Carbide.
- +.000 -.001 Cutting Dia. Tolerance.
- 30 Deg. CNC - Qualified Helix.



## STANDARD LENGTH FLAT END MILLS

PART NUMBER	CUT. DIA.	FLUTE LENGTH	SHANK DIA.	OAL	PRICE
12001698*	1/64	1/32	1/8	1-1/2	\$27.00
14003298	1/32	3/32	1/8	1-1/2	\$19.25
14004798	3/64	1/8	1/8	1-1/2	\$19.25
14006298	1/16	1/4	1/8	1-1/2	\$17.50
14007898	5/64	1/4	1/8	1-1/2	\$17.50
14009398	3/32	3/8	1/8	1-1/2	\$17.50
14010998	7/64	3/8	1/8	1-1/2	\$17.50
14012598	1/8	1/2	1/8	1-1/2	\$21.00
14015698	5/32	9/16	3/16	2"	\$26.50
14018798	3/16	5/8	3/16	2"	\$27.00
14025098	1/4	3/4	1/4	2-1/2	\$33.50
14031298	5/16	7/8	5/16	2-1/2	\$41.00
14037598	3/8	7/8	3/8	2-1/2	\$45.00
14050098	1/2	1"	1/2	3"	\$74.00

\* 2 FLUTE TOOL



## EXTRA LENGTH FLAT END MILLS

PART NUMBER	CUT. DIA.	FLUTE LENGTH	SHANK DIA.	OAL	PRICE
14112598	1/8	5/8	1/8	2"	\$25.00
14412598	1/8	1"	1/8	3"	\$29.00
14118798	3/16	1"	3/16	3"	\$30.00
14218798	3/16	1-1/8	3/16	3"	\$33.00
14318798	3/16	1"	3/16	4"	\$40.00
14125098	1/4	1"	1/4	3"	\$37.00
14425098	1/4	1-1/2	1/4	4"	\$41.00
14525098	1/4	1-1/2	1/4	6"	\$46.00
14131298	5/16	1"	5/16	3"	\$46.00
14431298	5/16	1-5/8	5/16	4"	\$51.00
14531298	5/16	1-1/2	5/16	6"	\$58.00
14137598	3/8	1"	3/8	3"	\$53.00
14437598	3/8	2"	3/8	4"	\$61.00
14537598	3/8	1-1/2	3/8	6"	\$67.00
14250098	1/2	2"	1/2	4"	\$99.00
14650098	1/2	3"	1/2	6"	\$124.00
14562598	5/8	2"	5/8	6"	\$175.00
14662598	5/8	3"	5/8	6"	\$216.00
14575098	3/4	2"	3/4	6"	\$201.00
14675098	3/4	3"	3/4	6"	\$252.00
14500098	1"	2"	1"	6"	\$350.00
14600098	1"	3"	1"	6"	\$381.00

AD-98 Diamond Coated End Mills have shown tool life increases of 5-10 times over uncoated or PVD metallic coated end mills. Priced between PVD films and CVD diamond, the advantage is AD-98's coating delivers more parts at a lower cost per part with excellent finishes. AD-98 diamond coating has the hardness of diamond and the friction coefficient of lapped diamond.

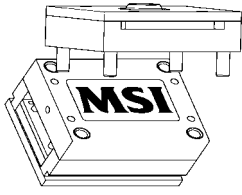

# AD-98 END MILLS

FOR MACHINING GRAPHITE AND CARBON COMPOSITES

- ISO H6 Shank Tolerance for Shrink Fit Holders.
- Made From Ultra-Fine Micro Grain Carbide.
- +.000 -.001 Cutting Dia. Tolerance.
- 30 Deg. CNC - Qualified Helix.



## STANDARD LENGTH BALL END MILLS

PART NUMBER	CUT. DIA.	FLUTE LENGTH	SHANK DIA.	OAL	PRICE
22001698*	1/64	1/32	1/8	1-1/2	\$31.50
24003298	1/32	3/32	1/8	1-1/2	\$22.00
24004798	3/64	1/8	1/8	1-1/2	\$22.00
24006298	1/16	1/4	1/8	1-1/2	\$19.50
24007898	5/64	1/4	1/8	1-1/2	\$19.50
24009398	3/32	3/8	1/8	1-1/2	\$19.50
24010998	7/64	3/8	1/8	1-1/2	\$19.50
24012598	1/8	1/2	1/8	1-1/2	\$22.50
24015698	5/32	9/16	3/16	2"	\$28.50
24018798	3/16	5/8	3/16	2"	\$29.00
24025098	1/4	3/4	1/4	2-1/2	\$36.50
24031298	5/16	7/8	5/16	2-1/2	\$44.00
24037598	3/8	7/8	3/8	2-1/2	\$49.00
24050098	1/2	1"	1/2	3"	\$80.00

\* 2 FLUTE TOOL



## EXTRA LENGTH BALL END MILLS

PART NUMBER	CUT. DIA.	FLUTE LENGTH	SHANK DIA.	OAL	PRICE
24112598	1/8	5/8	1/8	2"	\$26.50
24412598	1/8	1"	1/8	3"	\$32.00
24118798	3/16	1"	3/16	3"	\$33.00
24218798	3/16	1-1/8	3/16	3"	\$36.50
24318798	3/16	1"	3/16	4"	\$43.00
24125098	1/4	1"	1/4	3"	\$41.00
24425098	1/4	1-1/2	1/4	4"	\$45.50
24525098	1/4	1-1/2	1/4	6"	\$50.50
24131298	5/16	1"	5/16	3"	\$49.50
24431298	5/16	1-5/8	5/16	4"	\$56.00
24531298	5/16	1-1/2	5/16	6"	\$62.00
24137598	3/8	1"	3/8	3"	\$59.00
24437598	3/8	2"	3/8	4"	\$69.00
24537598	3/8	1-1/2	3/8	6"	\$76.00
24250098	1/2	2"	1/2	4"	\$110.00
24650098	1/2	3"	1/2	6"	\$140.00
24562598	5/8	2"	5/8	6"	\$191.00
24662598	5/8	3"	5/8	6"	\$245.00
24575098	3/4	2"	3/4	6"	\$226.00
24675098	3/4	3"	3/4	6"	\$287.00
24500098	1"	2"	1"	6"	\$401.00
24600098	1"	3"	1"	6"	\$435.00

AD-98 Diamond Coated End Mills have shown tool life increases of 5-10 times over uncoated or PVD metallic coated end mills. Priced between PVD films and CVD diamond, the advantage is AD-98's coating delivers more parts at a lower cost per part with excellent finishes. AD-98 diamond coating has the hardness of diamond and the friction coefficient of lapped diamond.

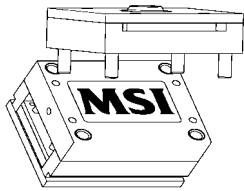

# AD-99 MINI MILLS

FOR MACHINING GRAPHITE AND CARBON COMPOSITES

- ISO H6 Shank Tolerance for Shrink Fit Holders.
- +.000 -.001 Cutting Dia. Tolerance.
- Made From Ultra-Fine Micro Grain Carbide.
- 30 Deg. CNC - Qualified Helix.

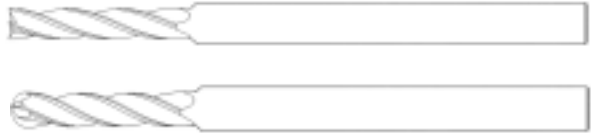

## BALL AND FLAT BOTTOM MINI MILLS

CATALOG NUMBER	END MILL TYPE	CUTTING DIA.	SHANK DIA.	FLUTE LENGTH	OAL	PRICE
14703199	FLAT	0.032	1/8	0.15	3"	\$28.50
14903199	FLAT	0.032	1/8	0.15	2"	\$28.50
14703299	FLAT	0.032	1/8	1/4	3"	\$30.50
14903299	FLAT	0.032	1/8	1/4	2"	\$30.50
14704799	FLAT	0.047	1/8	1/4	3"	\$26.50
14904799	FLAT	0.047	1/8	1/4	2"	\$26.50
14706299	FLAT	0.062	1/8	1/2	3"	\$27.50
14906299	FLAT	0.062	1/8	1/2	2"	\$27.50
14708099	FLAT	0.080	1/8	1/2	3"	\$28.50
14908099	FLAT	0.080	1/8	1/2	2"	\$28.50
14709499	FLAT	0.094	1/8	3/4	3"	\$29.50
14909499	FLAT	0.094	1/8	3/4	2"	\$29.50
24703199	BALL	0.032	1/8	0.15	3"	\$30.50
24903199	BALL	0.032	1/8	0.15	2"	\$30.50
24703299	BALL	0.032	1/8	1/4	3"	\$32.50
24903299	BALL	0.032	1/8	1/4	2"	\$32.50
24704799	BALL	0.047	1/8	1/4	3"	\$28.50
24904799	BALL	0.047	1/8	1/4	2"	\$28.50
24706299	BALL	0.062	1/8	1/2	3"	\$29.50
24906299	BALL	0.062	1/8	1/2	2"	\$29.50
24708099	BALL	0.080	1/8	1/2	3"	\$30.50
24908099	BALL	0.080	1/8	1/2	2"	\$30.50
24709499	BALL	0.094	1/8	3/4	3"	\$31.50
24909499	BALL	0.094	1/8	3/4	2"	\$31.50

## FLAT BOTTOM - .015 CORNER RADIUS

CATALOG NUMBER	MILL TYPE	CUTTING DIA.	CORNER RADIUS	FLUTE LENGTH	SHANK DIAMETER	OAL	PRICE
34704799	FLAT	0.047	0.015	1/2	1/8	3"	\$28.50
34706299	FLAT	0.062	0.015	1/2	1/8	3"	\$29.50
34708099	FLAT	0.080	0.015	1/2	1/8	3"	\$30.50
34709499	FLAT	0.094	0.015	3/4	1/8	3"	\$31.50

AD-99 Diamond Coated End Mills have shown tool life increases of 5-10 times over uncoated or PVD metallic coated end mills. Priced between PVD films and CVD diamond, the advantage is AD-99's coating delivers more parts at a lower cost per part with excellent finishes. AD-99 diamond coating has the hardness of diamond and the friction coefficient of lapped diamond.

FOR PRICING INFO. SEE PAGE 1

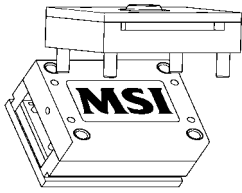

# AD-99 Clearance Mills

- ISO H6 Shank Tolerance for Shrink Fit Holders.
- +.000 -.001 Cutting Dia. Tolerance.
- Made From Ultra-Fine Micro Grain Carbide.
- 30 Deg. CNC - Qualified Helix.



Catalog Number	Radius	Cutting Dia.	Shank Dia.	Flute Length	Eff. Length	OAL	Price
22801099	BALL	0.010	1/8	0.020	0.050	3"	\$41.00
22802099	BALL	0.020	1/8	0.040	0.187	3"	\$41.00
24803099	BALL	1/32	1/8	0.150	0.400	3"	\$39.50
24803199	BALL	1/32	1/8	0.150	0.625	3"	\$39.50
24803399	BALL	1/32	1/8	0.150	0.900	3"	\$39.50
24804799	BALL	3/64	1/8	0.250	0.750	3"	\$39.50
24806199	BALL	1/16	1/8	0.250	0.750	3"	\$39.50
24806399	BALL	1/16	1/8	0.250	1.000	3"	\$39.50
24809399	BALL	3/32	1/8	0.250	1.000	3"	\$39.50
34803099	0.005	1/32	1/8	0.150	0.400	3"	\$39.50
34803199	0.005	1/32	1/8	0.150	0.625	3"	\$39.50
34803299	0.005	1/32	1/8	0.150	0.906	3"	\$39.50
34806299	0.010	1/16	1/8	0.250	0.750	3"	\$39.50
34806399	0.010	1/16	1/8	0.250	1.000	3"	\$39.50
34809299	0.010	3/32	1/8	0.250	1.000	3"	\$39.50

FOR PRICING INFO. SEE PAGE 1

*AD-99 Diamond Coated End Mills have shown tool life increases of 5-10 times over uncoated or PVD metallic coated end mills. Priced between PVD films and CVD diamond, the advantage is AD-99's coating delivers more parts at a lower cost per part with excellent finishes. AD-99 diamond coating has the hardness of diamond and the friction coefficient of lapped diamond.*

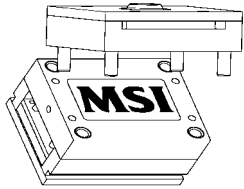

# Diabide CVD Diamond End Mills

Tight tolerance for precision machining. 30 degree CNC qualified helix.



TOLERANCES	
+0.000 -0.0005	Cutting Diameter Tolerance
-0.0001 -0.0003	Shank Diameter Tolerance

End mills fit standard tool adapters, collet and hydraulic chucks, and shrink fit holders

Cat. No.	Flutes	Flute Dia.	Shank Dia.	Flt. Length	Eff. Length	Radius	OAL	Price
12003103	2	1/32	1/8	3/32		FLAT	2"	\$90.00
12803103	2	1/32	1/8	3/32	1/4	FLAT	2"	\$95.00
14703203	4	1/32	1/8	1/4		FLAT	3"	\$90.00
14803103	4	1/32	1/8	3/32	5/16	FLAT	2"	\$95.00
14903203	4	1/32	1/8	1/4		FLAT	2"	\$90.00
14804603	4	3/64	1/8	1/8	7/32	FLAT	2"	\$95.00
14706203	4	1/16	1/8	1/2		FLAT	3"	\$100.00
14806203	4	1/16	1/8	1/4	5/8	FLAT	2"	\$95.00
14806303	4	1/16	1/8	1/4	1/2	FLAT	2"	\$95.00
14906203	4	1/16	1/8	1/2		FLAT	2"	\$90.00
14807803	4	5/64	1/8	1/4	1/2	FLAT	2"	\$95.00
14209403	4	3/32	1/8	1/2		FLAT	2"	\$90.00
14709403	4	3/32	1/8	3/4		FLAT	3"	\$100.00
14809303	4	3/32	1/8	3/8	15/16	FLAT	2"	\$100.00
14909403	4	3/32	1/8	3/4		FLAT	2"	\$95.00
14012503	4	1/8	1/8	1/2		FLAT	2"	\$90.00
14412503	4	1/8	1/8	1"		FLAT	3"	\$105.00
14018703	4	3/16	3/16	5/8		FLAT	2"	\$112.00
14118703	4	3/16	3/16	1"		FLAT	4"	\$130.00
14025003	4	1/4	1/4	3/4		FLAT	2-1/2"	\$120.00
14125003	4	1/4	1/4	3/4		FLAT	3"	\$130.00
14425003	4	1/4	1/4	1-1/2		FLAT	4"	\$150.00
14037503	4	3/8	3/8	7/8		FLAT	2-1/2"	\$157.00
14237503	4	3/8	3/8	1-1/2		FLAT	4"	\$180.00
14050003	4	1/2	1/2	1"		FLAT	3"	\$190.00

## INSERTS

Cat. No.	Description	Price
APKT1003PDR CVD	ISCAR W/ .019 RADIUS	\$55.00
FB0250N01 CVD	1/4" MILLSTAR W/ .015 RAD	\$80.00
RBS0250FS CVD	1/4" MILLSTAR BALL	\$80.00
FB0375N02 CVD	3/8 MILLSTAR W/ .032 RAD	\$85.00
FB0500N02 CVD	1/2" MILLSTAR W/ .032 RAD	\$88.30
FB0500N04 CVD	1/2" MILLSTAR W/ .062 RAD	\$88.30
TO0500 CVD	1/2" MILLSTAR TOROID	\$88.30

Cat. No.	Description	Price
FB0750R02 CVD	3/4" MILLSTAR W/ .032 RAD	\$130.00
FB0750N04 CVD	3/4" MILLSTAR W/ .062 RAD	\$130.00
FB0750N08 CVD	3/4" MILLSTAR W/ .125 RAD	\$130.00
FB1000N04 CVD	1" MILLSTAR W/ .062 RAD	\$160.00
FB1000N08 CVD	1" MILLSTAR W/ .125 RAD	\$160.00

FOR PRICING INFO. SEE PAGE 1

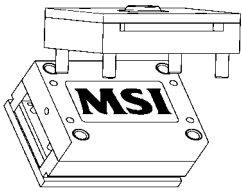

# Diabide CVD Diamond Ball Mills

**Tight tolerance for precision machining. 30 degree CNC qualified helix.**



TOLERANCES	
+ .000 - .0005	Cutting Diameter Tolerance
- .0001 - .0003	Shank Diameter Tolerance

End mills fit standard tool adapters, collet and hydraulic chucks, and shrink fit holders

Cat. No.	Flutes	Flute Dia.	Shank Dia.	Flt. Length	Eff. Length	OAL	Price
22001603	2	1/64	1/8	1/32		2"	\$115.00
22003103	2	1/32	1/8	3/32		2"	\$95.00
22803103	2	1/32	1/8	3/32	1/4	2"	\$99.00
24703203	4	1/32	1/8	1/4		3"	\$95.00
24803103	4	1/32	1/8	3/32	5/16	2"	\$99.00
24903203	4	1/32	1/8	1/4		2"	\$95.00
24804603	4	3/64	1/8	1/8	7/32	2"	\$99.00
24706203	4	1/16	1/8	1/2		3"	\$100.00
24806203	4	1/16	1/8	1/4	5/8	2"	\$99.00
24806303	4	1/16	1/8	1/4	1/2	2"	\$99.00
24806403	4	1/16	1/8	1/4	3/4	2"	\$99.00
24806503	4	1/16	1/8	1/4	1"	2"	\$99.00
24906203	4	1/16	1/8	1/2		2"	\$95.00
24807803	4	5/64	1/8	1/4	1/2	2"	\$99.00
24209403	4	3/32	1/8	1/2		2"	\$95.00
24709403	4	3/32	1/8	3/4		3"	\$100.00
24809303	4	3/32	1/8	3/8	15/16	2"	\$99.00
24909403	4	3/32	1/8	3/4		2"	\$99.00
24012503	4	1/8	1/8	1/2		2"	\$95.00
24212503	4	1/8	1/8	1/4		3"	\$99.00
24412503	4	1/8	1/8	1"		3"	\$105.00
24512503	4	1/8	1/8	1"		4"	\$110.00
24812503	4	1/8	1/8	3/16	1"	2"	\$105.00
24018703	4	3/16	3/16	5/8		2"	\$118.00
24118703	4	3/16	3/16	1"		4"	\$140.00
24318703	4	3/16	3/16	1/2		3"	\$125.00
24818703	4	3/16	3/16	3/16	1-3/16	2"	\$150.00
24025003	4	1/4	1/4	3/4		2-1/2	\$140.00
24125003	4	1/4	1/4	3/4		3"	\$145.00
24325003	4	1/4	1/4	3/4		4"	\$145.00
24425003	4	1/4	1/4	1-1/2		4"	\$150.00
24525003	4	1/4	1/4			6"	\$160.00
24825003	4	1/4	1/4	1/4	1-1/4	2"	\$145.00
24037503	4	3/8	3/8	7/8		2-1/2	\$160.00
24237503	4	3/8	3/8	1-1/2		4"	\$185.00
24337503	4	3/8	3/8	1"		4"	\$185.00
24537503	4	3/8	3/8	2"		6"	\$190.00
24050003	4	1/2	1/2	1"		3"	\$195.00
24350003	4	1/2	1/2	1"		4"	\$200.00
24550003	4	1/2	1/2	2"		6"	\$315.00

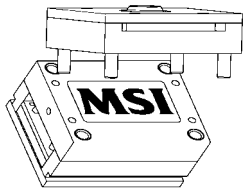

# Diabide CVD Diamond End Mills

## With Corner Radius

Tight tolerance for precision machining. 30 degree CNC qualified helix.



TOLERANCES	
+0.000 -0.0005	Cutting Diameter Tolerance
-0.0001 -0.0003	Shank Diameter Tolerance

End mills fit standard tool adapters, collet and hydraulic chucks, and shrink fit holders

Cat. No.	Flutes	Flute Dia.	Shank Dia.	Flt. Length	Eff. Length	Radius	OAL	Price
34003203	4	1/32	1/8	3/32		0.005	1-1/2	\$95.00
34803103	4	1/32	1/8	0.15	5/8	0.005	2"	\$99.00
34806103	4	1/16	1/8	1/4	1/2	0.010	2"	\$99.00
34806303	4	1/16	1/8	1/4	1/2	0.015	2"	\$99.00
34112503	4	1/8	1/8	1/2		0.015	2"	\$95.00
34212503	4	1/8	1/8	1/2		0.030	2"	\$95.00
34312503-030	4	1/8	1/8	1/4		0.030	3"	\$99.00
34512503-030	4	1/8	1/8	1/4		0.030	4"	\$110.00
34118703	4	3/16	3/16	3/4		0.060	2"	\$120.00
34218703-030	4	3/16	3/16	3/8		0.030	3"	\$125.00
34318703-030	4	3/16	3/16	3/8		0.030	4"	\$140.00
34818703	4	3/16	3/16	3/16	1-3/16	0.015	2"	\$125.00
34025003	4	1/4	1/4	3/4		0.015	2"	\$140.00
34125003	4	1/4	1/4	3/4		0.060	3"	\$145.00
34325003	4	1/4	1/4	3/4		0.015	3"	\$140.00
34425003	4	1/4	1/4	1"		0.030	4"	\$145.00
34325003-030	4	1/4	1/4	3/8		0.030	4"	\$145.00
34225003-060	4	1/4	1/4	3/8		0.060	4"	\$145.00
34225003-030	4	1/4	1/4	3/8		0.030	6"	\$160.00
34525003-060	4	1/4	1/4	3/8		0.060	6"	\$160.00
34825003	4	1/4	1/4	1/4	1-1/4	0.015	2"	\$150.00
34137503	4	3/8	3/8	1"		0.030	2-1/2	\$160.00
34337503-030	4	3/8	3/8	1/2		0.030	4"	\$185.00
34337503-060	4	3/8	3/8	1/2		0.060	4"	\$185.00
34537503-030	4	3/8	3/8	1/2		0.030	6"	\$190.00
34537503-060	4	3/8	3/8	1/2		0.060	6"	\$190.00
34837503	4	3/8	3/8	3/8	1"	0.015	2"	\$150.00
34837603	4	3/8	3/8	3/8	2"	0.015	3"	\$150.00
34150003	4	1/2	1/2	1		0.060	4"	\$200.00
34350003-030	4	1/2	1/2	1/2		0.030	4"	\$200.00
34350003-060	4	1/2	1/2	1/2		0.060	4"	\$200.00
34550003-030	4	1/2	1/2	1/2		0.030	6"	\$210.00
34550003-060	4	1/2	1/2	1/2		0.060	6"	\$210.00

FOR PRICING INFO. SEE PAGE 1

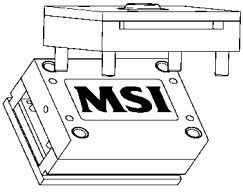

# Socket Head Cap Screw Counterbore Tool

- 4 TIMES FASTER THAN HSS
- USES STANDARD ISCAR INSERT (SOMT 06..)
- 4 EDGES PER INSERT
- POSITIVE CHIPBREAKER FOR CHIP CONTROL & FREE CUTTING

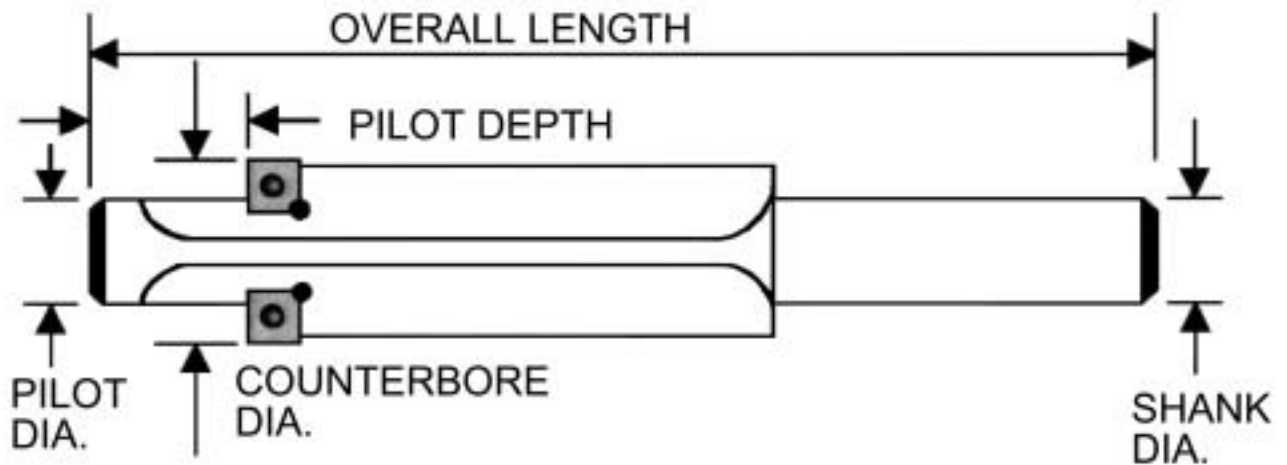

CATALOG NUMBER	SHCS SIZE	PILOT DIA.	CB DIA.	OAL	PILOT DEPTH	SHANK DIA.	RPM	IRP	NO. OF FLUTES	SCREW	TORX	PRICE
CSCB-14	1/4	0.280	0.406	3.250	0.250	0.500	3500	0.002	1	SR34-508	T-7	\$95.00
CSCB-516	5/16	0.342	0.500	3.500	0.312	0.500	3100	0.003	1	SR34-508	T-7	\$95.00
CSCB-38	3/8	0.405	0.594	3.625	0.312	0.500	2700	0.006	2	SR34-508	T-7	\$138.00
CSCB-716	7/16	0.467	0.687	3.750	0.375	0.500	2500	0.008	2	SR34-508	T-7	\$144.00
CSCB-12	1/2	0.530	0.781	4.000	0.375	0.750	2200	0.008	2	SR34-508	T-7	\$144.00
CSCB-58	5/8	0.655	1.000	4.125	0.500	0.750	1800	0.008	2	SR34-508	T-7	\$156.00
CSCB-34	3/4	0.812	1.187	4.250	0.500	0.750	1500	0.008	2	SR34-508	T-7	\$168.00
CSCB-KIT	INCLUDES ALL ABOVE CUTTERS -- SAVE 25% OFF LIST PRICE!											\$705.00

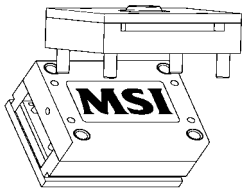

# Button Plunge Mills

- General purpose milling.
- Custom sizes available.
- Used for roughing or multi-purpose.
- Ability to plunge and ramp in any direction.

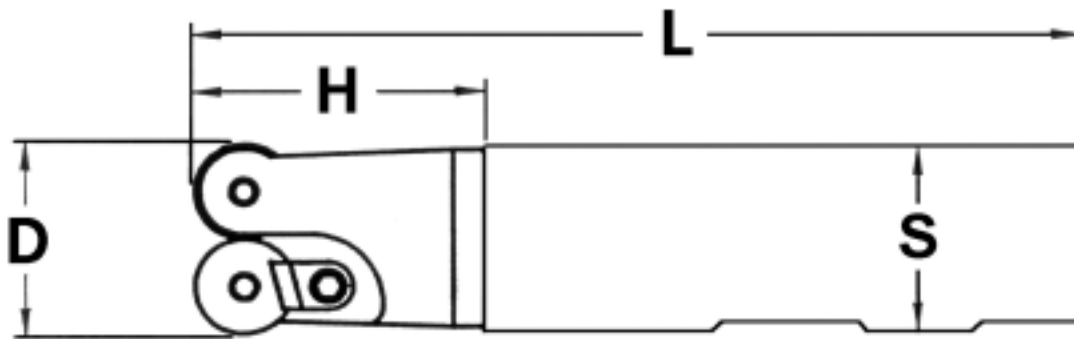

CATALOG NUMBER	CUTTING DIA. (D)	NUMBER OF FLUTES	EFFECTIVE LENGTH (H)	OVERALL LENGTH (L)	SHANK DIA. (S)	INSERT NUMBER	SCREW NUMBER	CLAMP NUMBER	PRICE
KPM100-4R43	1.00	2	1.5	4"	1.000	RPG-43	SR14-544S	TC-1	\$159.00
KPM100-6R43	1.00	2	1.5	6"	1.000	RPG-43	SR14-544S	TC-1	\$179.00
KPM100-8R43	1.00	2	1.5	8"	1.000	RPG-43	SR14-544S	TC-1	\$189.00
KPM100-10R43	1.00	2	1.5	10"	1.000	RPG-43	SR14-544S	TC-1	\$209.00
KPM125-8R43	1.25	3	1.5	8"	1.250	RPG-43	SR14-544S	TC-1	\$199.00
KPM125-10R43	1.25	3	1.5	10"	1.250	RPG-43	SR14-544S	TC-1	\$209.00
KPM125-4R53	1.25	2	1.5	4"	1.250	RPG-53	TS-12B	TC-2	\$219.00
KPM125-6R53	1.25	2	1.5	6"	1.250	RPG-53	TS-12B	TC-2	\$240.00
KPM125-8R53	1.25	2	1.5	8"	1.250	RPG-53	TS-12B	TC-2	\$250.00
KPM125-10R53	1.25	2	1.5	10"	1.250	RPG-53	TS-12B	TC-2	\$260.00
KPM150-8R43	1.50	3	1.5	8"	1.250	RPG-43	SR14-544S	TC-1	\$249.00
KPM150-8R64	1.50	2	1.5	8"	1.500	RPG-64	TS-20S	TC-2	\$439.00
KPM200-8R84	2.00	2	2	8"	2.000	RPG-84	TS-20	TC-4	\$449.00

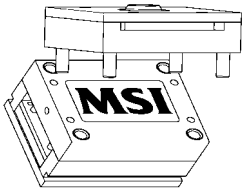

# Button Plunge Mills

- General purpose milling.
- Used for roughing or multi-purpose.

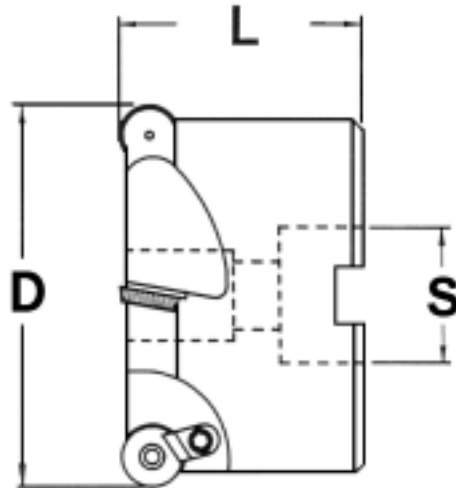

CATALOG NUMBER	CUTTING DIAMETER (D)	HOLE DIAMETER (S)	NUMBER OF FLUTES	INSERT NUMBER	SCREW NUMBER	CLAMP NUMBER	PRICE
KPM200R43-4	2.000	0.750	4	RPG-43	SR14-544S	TC-1	\$239.00
KPM200R43-5	2.000	0.750	5	RPG-43	SR14-544S	TC-1	\$249.00
KPM200R53-3	2.000	0.750	3	RPG-53	TS-12B	TC-2	\$239.00
KPM300R43-5	3.000	1.000	5	RPG-43	SR14-544S	TC-1	\$435.00
KPM300R43-6	3.000	1.000	6	RPG-43	SR14-544S	TC-1	\$449.00
KPM300R53-5	3.000	1.000	5	RPG-53	TS-12B	TC-2	\$435.00
KPM300R64-5	3.000	1.000	5	RPG-64	TS-20S	TC-2	\$419.00
KPM400R64-5	4.000	1.500	5	RPG-64	TS-20S	TC-2	\$535.00
KPM400R84-5	4.000	1.500	5	RPG-84	TS-20	TC-4	\$550.00
KPM450R53-5	4.500	1.500	5	RPG-53	TS-12B	TC-2	\$600.00
KPM450R53-6	4.500	1.500	6	RPG-53	TS-12B	TC-2	\$600.00
KPM500R64-5	5.000	1.500	5	RPG-64	TS-20S	TC-2	\$650.00
KPM600R64-6	6.000	1.500	6	RPG-64	TS-20S	TC-2	\$770.00
KPM600R84-5	6.000	1.500	5	RPG-84	TS-20	TC-4	\$770.00



# Button Cutter Inserts

These inserts are available in a non-coated grade or a MS-1 coated grade in both chipbreaker and non-chipbreaker styles in a variety of sizes. MS-3 Coating is an advanced titanium aluminum nitride PVD coating. It is a special, improved TiAlN coating approaching the surface hardness of CBN. The inserts are also available in TiN and TiCN grades - please call for pricing.

- RPGA Denotes Plain
- RPGW Denotes Chipbreaker

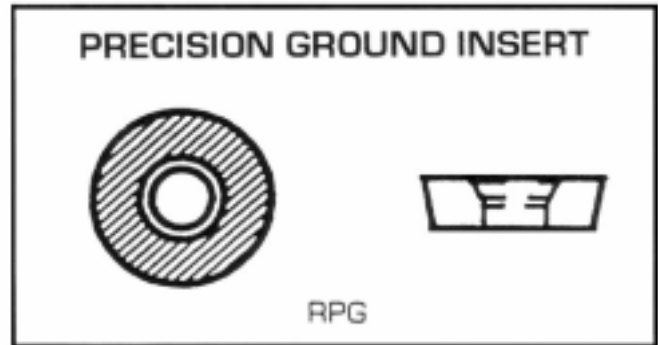

CATALOG NUMBER	GRADE	DIAMETER	PRICE				
			10	30	50	100	150+
RPGA-43	NC	1/2	\$7.95	\$6.75	\$6.08	\$5.47	\$4.93
RPGA-43	MS-3	1/2	\$10.75	\$9.15	\$8.21	\$7.40	\$6.65
RPGW-43	NC	1/2	\$7.95	\$6.75	\$6.08	\$5.47	\$4.93
RPGW-43	MS-3	1/2	\$10.75	\$9.15	\$8.21	\$7.40	\$6.65
RPGA-53	NC	5/8	\$9.92	\$8.43	\$7.59	\$6.85	\$6.15
RPGA-53	MS-3	5/8	\$12.95	\$11.10	\$9.59	\$9.00	\$8.08
RPGW-53	NC	5/8	\$9.92	\$8.43	\$7.59	\$6.85	\$6.15
RPGW-53	MS-3	5/8	\$12.95	\$11.10	\$9.59	\$9.00	\$8.08
RPGA-64	NC	3/4	\$12.00	\$10.20	\$9.15	\$8.25	\$7.45
RPGA-64	MS-3	3/4	\$15.11	\$12.85	\$11.50	\$10.40	\$9.35
RPGW-64	NC	3/4	\$12.00	\$10.20	\$9.15	\$8.25	\$7.45
RPGW-64	MS-3	3/4	\$15.11	\$12.85	\$11.50	\$10.40	\$9.35
RPGA-84	NC	1"	\$17.16	\$14.50	\$13.00	\$11.80	\$10.65
RPGA-84	MS-3	1"	\$21.03	\$17.80	\$16.00	\$14.40	\$13.00
RPGW-84	NC	1"	\$17.16	\$14.50	\$13.00	\$11.80	\$10.65
RPGW-84	MS-3	1"	\$21.03	\$17.80	\$16.00	\$14.40	\$13.00